

**PROFESSIONAL AUDIO MIXER  
OPERATING MANUAL**

**Choice  
Select**  
*ULTRA*

**CHO3070**

**MX-8S**

**Audio Mixer with EFF. and EQ.**

---

**Keep the manual for your future needs!**

# MX -8S MIXER

8 Channels Mic/Line

## CONTENTS

- A. INTRODUCTION
- B. MONO INPUT CHANNELS
- C. STEREO CHANNEL SECTION
- D. MASTER SECTION
- E. INSTALLATION
- F. CONNECTIONS
- G. SPECIFICATION
- K. BLOCK DIAGRAM

## A. INTRODUCTION

- 4 Mono input channels with XLR, TRS and balanced line inputs
- Ultra-low noise discrete Mic Preamps with +48V Phantom Power
- 2 stereo input channels with balanced TRS and RCA
- 2 additional multi functional Stereo Line Inputs
- Extremely high headroom-offering more dynamic range
- Balanced input for high signal integrity
- Ultra-musical 3-band EQ on all channels
- Peak LEDs all Mono and stereo channels
- 1 Aux sends per channel for external effects and monitoring
- Separate Master Mix, control room and Headphone Outputs.
- 2-Track inputs assignable to Master Mix, control room/headphone output
- Highly accurate 10 segments Level Meters
- Rugged design Power Supply ensures superior signal integrity

# SAFETY INSTRUCTIONS

**CAUTION:** To reduce the risk of electrical shock, do not remove the cover(or back). No user serviceable parts inside; refer servicing to qualified personnel.

**WARNING:** To reduce the risk of fire or electrical shock, do not expose this appliance to rain or moisture.



## A. INTRODUCTION

Channels 1-4 of MX-8S are mono channels, with a choice of balanced Mic or Line inputs. The 4 other channels are stereo channels, they are convenient for MIDI signals and signals from electronic instruments. The AUX send function of this mixer is post-fader. The AUX return function has 2 outputs that can be linked to a MIDI receiver or an electronic instrument. All numbers below in brackets refer to figure 1.

## B. MONO INPUT CHANNELS

Every mono channel is fitted with an XLR microphone input (1) and a balanced TRS line input (2). Phantom power can be switched on at the rear panel (29). The trim circuit Features a large range from -10dB to +60dB.

Set the strength of the mic input signal via the trim control (3). Every channel is fitted with a PEAK LED (9). If it flashes or lights up, you have to reduce the signal. Otherwise the channel will be overloaded. Watch this LED especially if you use very heavy EQ settings (these LEDs show the post EQ signal).

Every mono input channel has its own 3 band EQ. The high button (4) sets the high frequencies, the mid button (5) the medium frequencies and the low button (6) the low frequencies. All three bands have a cut and boost up to 15dB and a center position of 0.

The AUX send (7) is post-fader. This button controls the signal strength to the AUX terminal. The gain to the master is set via the channel volume button (10).

The channel Pan (8) sets the position of the stereo output. Whatever the position may be there should be no difference in the volume level.

## C. STEREO INPUT CHANNELS

Every stereo channel has two TRS balanced inputs for a stereo line input signal. If only the left input is connected, this channel will work exactly as a mono channel.

The stereo inputs are designed for any line input signal. Most line sources such as MIDI instruments and FS units have their own output level control. The units without output level control such as CD players have an output level which is within the range of the MX-8S. If the channel and master faders are set to the same level, the Vu-meters will display a value between -4 and -7dB.

The only difference with the mono EQ is that a stereo channel includes no low-cut filter as this equalizer is stereo and not mono.

The AUX send function on a stereo channel works exactly as on a mono channel. The stereo signal should be bridged to a mono signal.

The only difference with a mono channel is the implementation of a balance/pan button (11). This button determines the balance between the left and right signal that is sent to the right and left master output. If a stereo channel is used in mono mode (only the right is connected) the balanced button operates as a pan control in mono mode.

## D. MASTER SECTION

The AUX send signal is applied to unbalanced TRS jacks (21). Set the input level of the effect unit to the output level of the mixer. If your effect unit is not fitted with a gain control, you can amplify the signal via the AUX send button (7) up to 15dB.

There is an additional stereo input (AUX Return) on your mixer. The level of this input can be set via the AUX return button (12). This input is permanently affected to the master output. If a connector is plugged into this input, the AUX return function works with a mono signal. This input allows you to create a wet mix.

The output level of the master section is displayed via a 10 LED barograph vu-meter (13). Two other LEDs indicate ON/OFF(14) and phantom power ON/OFF(15).

Peaks are shown on the vu-meter around the 0 level. If the vu-meter displays over a longer period of time +10dB for the signal, the master volume and / or the channel volume must be reduced. If this is not sufficient, you can still reduce the gain of that channel and / or the output level of the instrument of effect unit.

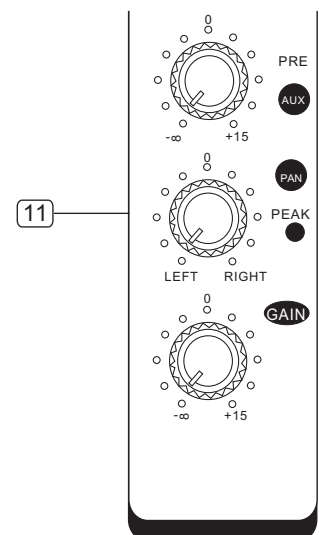
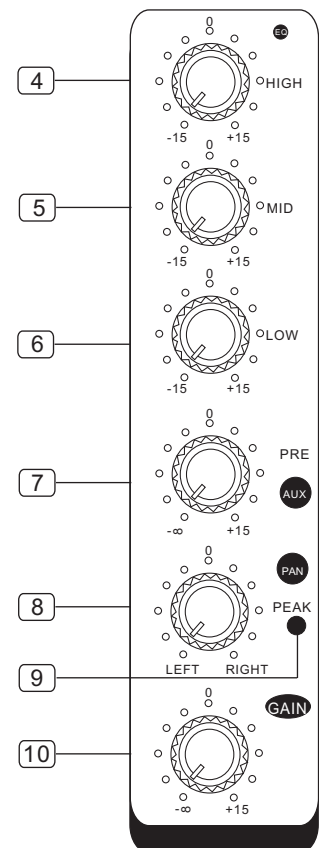
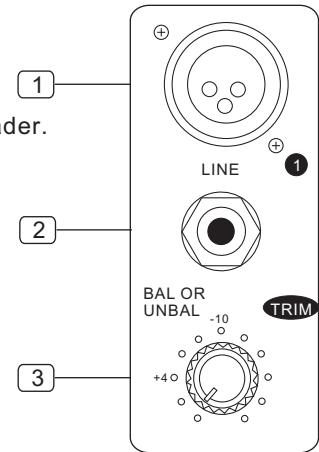

The RCA inputs are for connection of a CD player or a turntable. You can now route the signal via the "tape/rec to control room level" push button (17) to the studio monitors or to the master routes via the push button "tape/rec to master" (18). Make sure however that the push button (17) is in the UP position otherwise the signal will be input twice.

Connect the mixer to an amplifier via the balanced "stereo out" sockets (22). Use 2 6.3mm mono jacks for this connection. The total output volume is set via the master volume button (19).

The mixer is fitted with a separate headphone output (23). The signal is the same as from the control room output (27). The volume control (16) sends the signal to the headphones and the monitors. The L/R meters are the same as the same as the master output.

## E. INSTALLATION

Use care in making all cable connections correctly. Connect the leads one by one, checking each connection as you continue. Incorrect connections might permanently damage the unit. Figure 2 shows an example of possible connections.

Prior to connecting the mixer, set all controls to 0. You can connect microphone or line units to the mono channels, all kinds of line units to the stereo channels and effect units to the AUX return. You can also connect MIDI instruments to the AUX return.

If you connect a microphone, make sure that the phantom power is switched OFF. DO NOT use unbalanced units when the phantom power is switched on. Do not short-circuit the 48V circuit of the phantom power to the ground. You might damage the unit

If you record something on a DAT or ADAT recorder, do not set the maximum level. If your recorder can support a level of 96dB, record at a maximum level of 86-91dB. The peak level must always be 5-10 dB lower that the maximum level of your recorder.

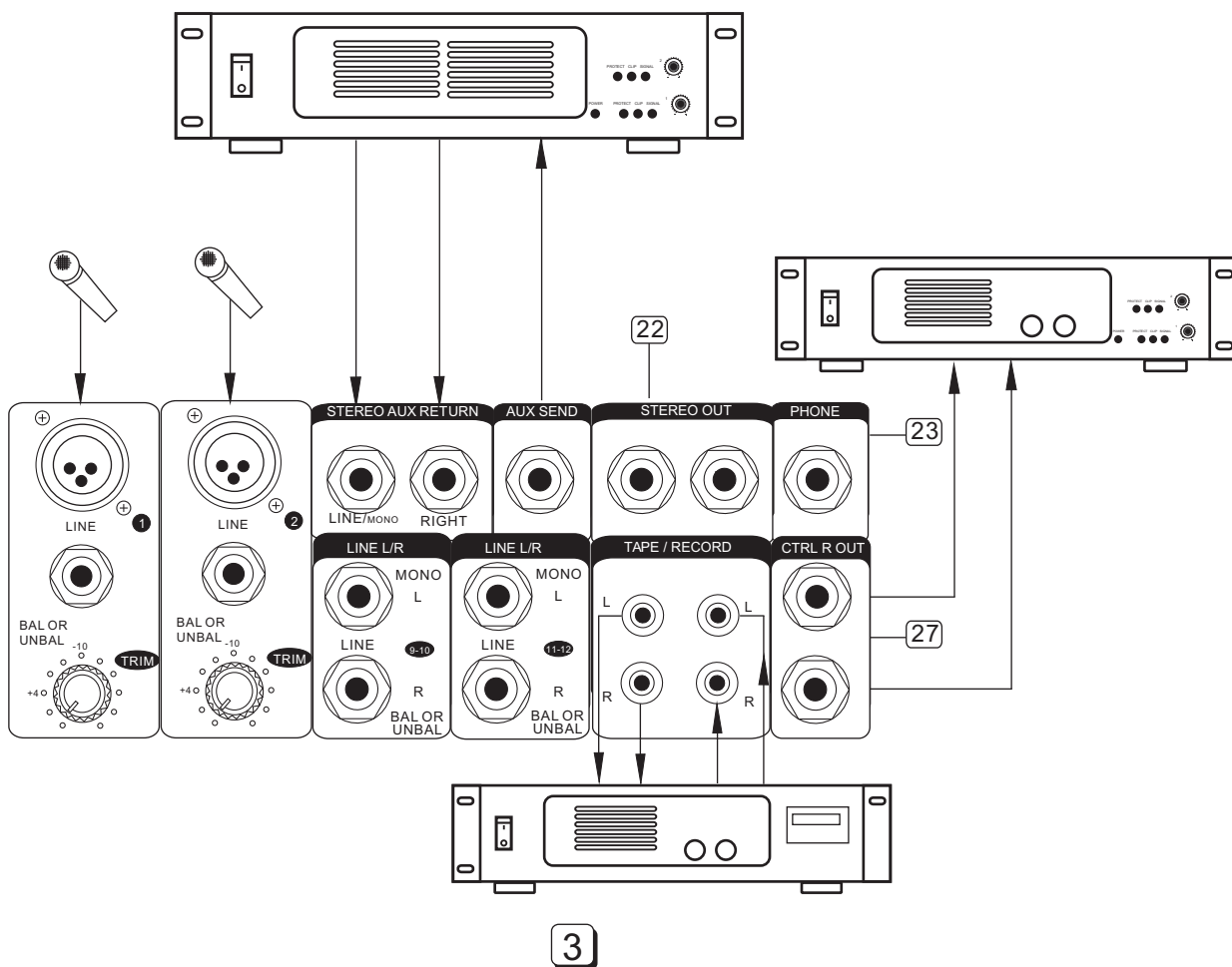
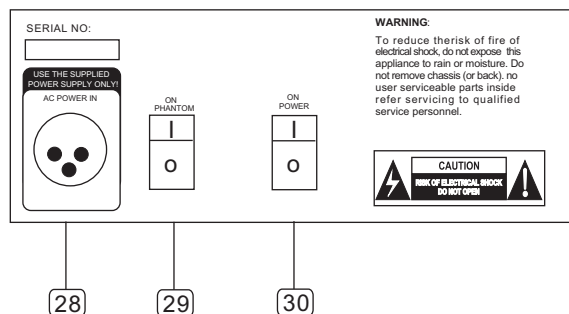
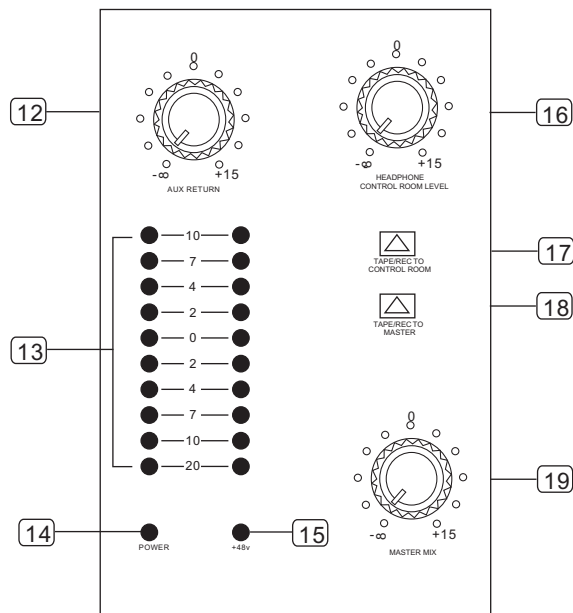

## F. CONNECTIONS

Refer to the following figures to make sure you use the correct connection cables.

unbalanced equipment may be connected to balanced inputs/outputs. Either use mono 1/4 jacks or connect ring and sleeve of TRS jacks.

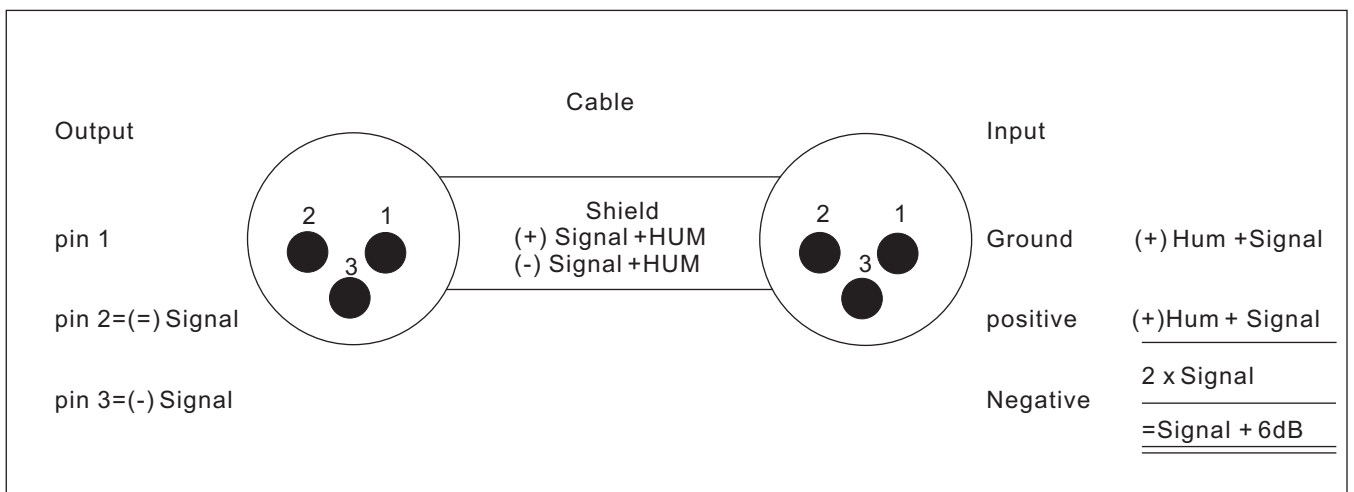
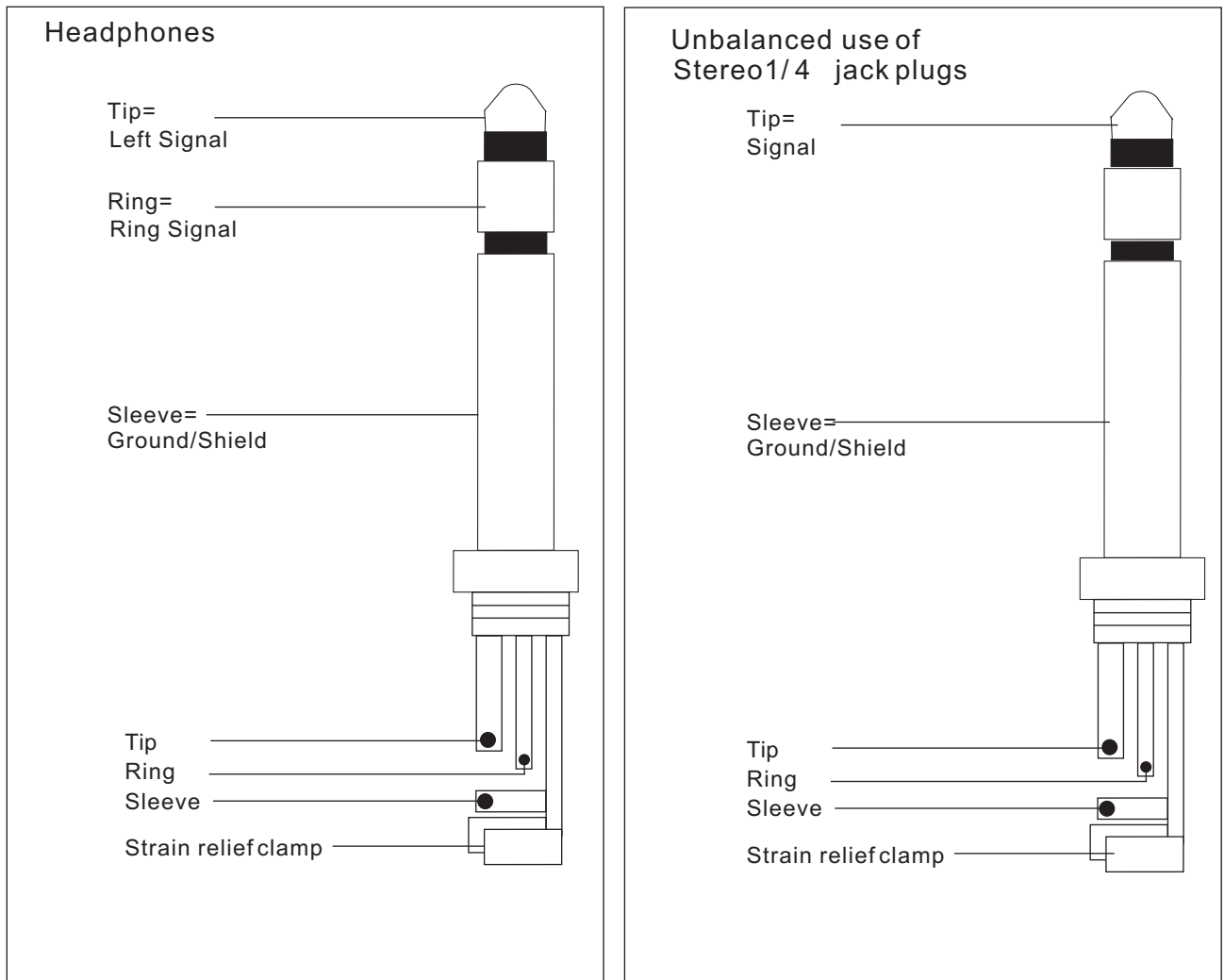

Fig. 6.2: Compensation of interference with balanced connections

### Unbalanced use of Stereo 1/4 jack plugs

Tip=  
Signal

Sleeve=  
Ground/Shield

Tip  
Ring  
Sleeve

Strain relief clamp

For connection of balanced and unbalanced plugs, ring and sleeve have to be bridged at the stereo plug.

### Balanced use with XLR connectors

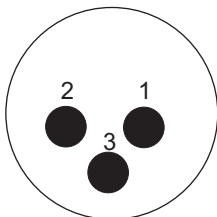

Input

1=Ground/Shield  
2=hot(+ve)  
3=cold(-ve)

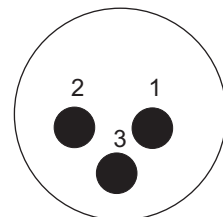

Output

For unbalanced use pin 1 and pin 3 have to be bridged

## G.SPECIFICATIONS

### Mono Inputs

Mic Input	Electronically balanced, discrete input configuration
Bandwidth	10Hz to 60KHz±3dB
Distortion (THD & N)	0.01% at +4dBu,1KHz,Bandwith 80KHz

### TRIM range

Line input	Electronically balanced
Bandwidth	10Hz to 60 KHz +-3dB
Distortion (THD & N)	0.01% at +4dBu,1KHz,Bandwith 80KHz
Line level range	+10dBu to -40dBu
Equalization	
Hi Shelving	12KHz +/-15dB
Mid Range	2.5KHz +/-15dB
Lo Shelving	80Hz +/-15dB

### Stereo Inputs

Line Input	Unbalanced
Bandwidth	10Hz to 55KHz +-3dB
Distortion (THD & N)	0.01% at +4dBu,1KHz,Bandwith 80KHz
Equalization	
Hi Shelving	12KHz +/-15dB
Mid Bell	2.5KHz +/-15dB
Lo Shelving	80Hz +/-15dB

### Master Mix Section

Max Output	+22dBu balanced
Send Max out	+22dBu unbalanced
G1 and G2 Max out	+22dBu unbalanced
Signal -To-Noise Ratio	112dB, all channels at Unity Gain

### Power Supply

Main Voltages	USA/Canada	120V AC, 60Hz, power supply unit MXUL2
---------------	------------	--

